

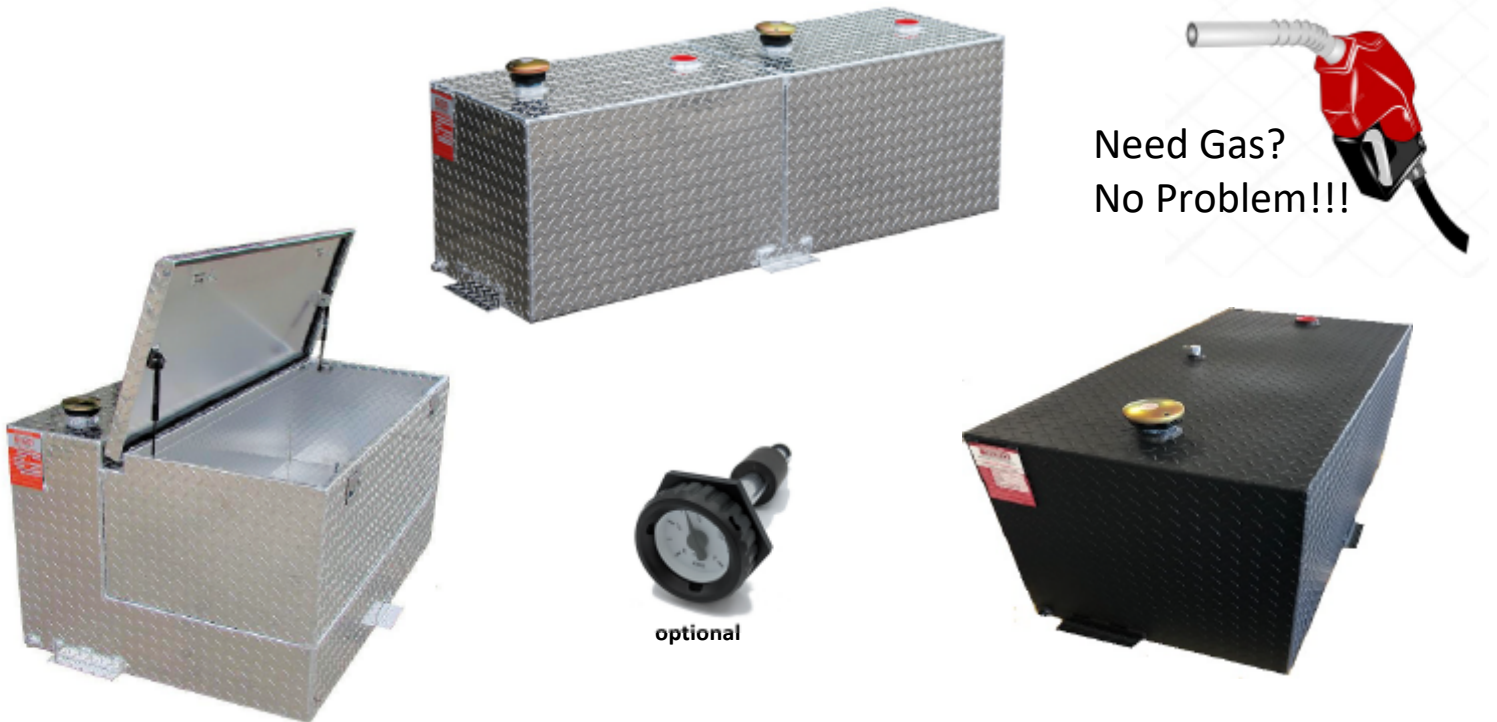

Aluminum Tank Industries, Inc.

ALUMINUM REFUELING TANKS



Need Gas?
No Problem!!!

Aluminum Tank Industries, Inc. has been issued a Special Permit from the U.S. Department Of Transportation for our Refueling Tanks. Our tanks can be used for gasoline, diesel, kerosene, aviation fuel, and methanol. Refueling tanks can be used in state, commercial, and private use applications.

- Special Permit issued by the US Department of Transportation
- Legal for **gas**, diesel, methanol, kerosene, aviation fuel and other liquids
- Commercial grade lockable vent/prevent filler cap
- Fully baffled to reduce movement of contents
- Two-2" npt reinforced bungs for superior strength
- 3/8" npt drain
- Hold down brackets
- Pressure and leak detection test
- Clean and free of debris inside and outside of the tank
- 1 year limited warranty





Table of Contents

Page#	Page Content
1	Refueling Tank Overview
2	Table of Contents
3	Refueling Tank Accessories
	L SHAPE TANKS
4	TTL50 - L shape 47 gallon refueling tank
5	TTL80 - L shape 80 gallon refueling tank
6	TTL95 - L shape 95 gallon refueling tank
7	TTL100 - L shape 100 gallon refueling tank
	SQUARE / RECTANGLE TANKS
8	TTR38 - Rectangle 38 gallon refueling tank
9	TTR42 - Rectangle 42 gallon refueling tank
10	TTR43 - Rectangle 43 gallon refueling tank
11	TTR46 - Rectangle 46 gallon refueling tank
12	TTR50 - Rectangle 50 gallon refueling tank
13	TTR51 - Rectangle 51 gallon refueling tank
14	TTR55 - Rectangle 55 gallon refueling tank
15	TTR58 - Rectangle 58 gallon refueling tank
16	TTR65 - Rectangle 62gallon refueling tank
17	TTR77 - Rectangle 77 gallon refueling tank
18	TTR110 - Rectangle 51 gallon refueling tank
	WEDGE TANKS
19	TTW60 - 60 gallon wedge shape tank
	DOUBLE WALL TANKS
20	TTR98DW - 98 gallon rectangle shape tank
21	TTR110DW - 110 gallon recatangle shape tank
	SPLIT TANKS
22	TTR72S- 36/36 gallon rectangle split tank
23	TTL85S- 42/42 gallon L shape split tank
24	TTL95S- 47/47 gallon L shape split tank
25	TTR110S- 55/55 gallon rectangle split tank
	TANK / TOOLBOX COMBOS
26	TTR42CB - 42 gallon rectangle with toolbox
27	TTL50CB- 47 gallon L shape with toolbox
28	TTR58CB9 - 58 gallon rectangle with toolbox
29	TTL95CB- 95 gallon L shape with toolbox
30	TTL95SCB- 47/47 gallon split tank with toolbox
	Severe Series
31	SSL95 - L shape 95 gal severe duty refueling tank
32	SSL95SCB- 47/47 gal severe duty split tank with toolbox
33	SSR110 - Rectangle 110 gal severe duty refueling tank



Aluminum Tank Industries, Inc.

REFUELING TANK OPTIONS AND ACCESSORIES

Part #	Pumps
BS-M150S-MU	GPI – 12v 15 gpm fuel transfer pump – Manual Nozzle
BS-M150S-AU	GPI – 12v 15 gpm fuel transfer pump – Automatic Nozzle
BS-EZ8	GPI – 12v 8 gpm fuel transfer pump – Manual Nozzle
BS-HP100-UL	GPI – Deluxe <i>Dual Flo</i> hand pump 50 Gal Per 100 Strokes



Part #	Pump Accessories
BS-M30-G8N	GPI - Mechanical fuel meter w/ strainer – 4 digit display
BS-FK	GPI - Filter kit - cast iron adapter-10 micron filter- nipple
BS-RF	GPI- Replacement filter 10 micron particulate (filter only)
BS-AN	Automatic shut off nozzle (nozzle only)



Part #	Tank Accessories
TTCAP	Vented lockable refueling tank cap w/ base
BS-RTCAP	Vented lockable replacement tank cap – NO base
BS-FLG	Rochester mechanical fluid level gauge
BS-LRTC	Spin Secure heavy duty keyed locking cap

	Tank Add-ons
Add "B" to end of part #	Powder Coat
	Additional npt fittings
	Notch out for pump



TTL50

[Return to Table of Contents](#)



Aluminum Tank Industries, Inc.

47 Gallon Refueling Tank



Mounting tabs extend out 1-1/2"
Add 2-1/2" for cap height

- Special Permit issued by the US Department of Transportation
- Legal for **gas**, diesel, methanol, kerosene, aviation fuel and other liquids
- Commercial grade lockable vent/prevent filler cap
- Fully baffled to reduce movement of contents
- Two-2" npt reinforced bungs for superior strength
- 3/8" npt drain
- Hold down brackets
- Pressure and leak detection test
- Clean and free of debris inside and outside of the tank
- 1 year limited warranty

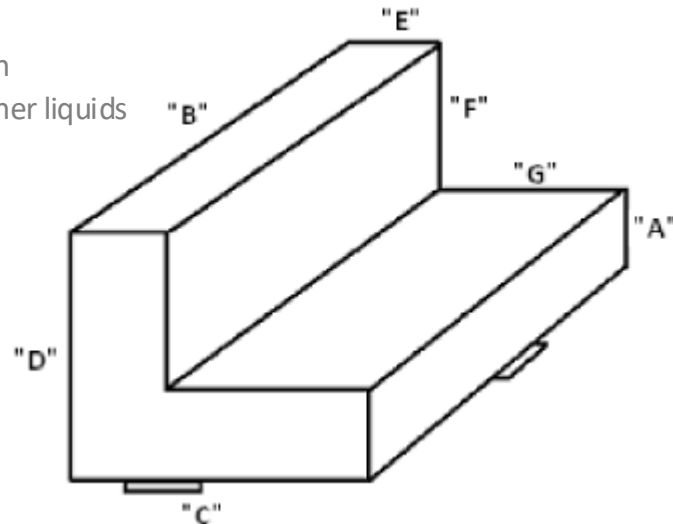

Part #	"A"	"B"	"C"	"D"	"E"	"F"	"G"	Gallons
TTL50	9"	36 1/4"	28"	18"	9"	9"	19"	47



Aluminum Tank Industries, Inc.

[Return to Table of Contents](#)

80 Gallon Refueling Tank



Mounting tabs extend out 1-1/2"
Add 2-1/2" for cap height

- Special Permit issued by the US Department of Transportation
- Legal for **gas**, diesel, methanol, kerosene, aviation fuel and other liquids
- Commercial grade lockable vent/prevent filler cap
- Fully baffled to reduce movement of contents
- Two-2" npt reinforced bungs for superior strength
- 3/8" npt drain
- Hold down brackets
- Pressure and leak detection test
- Clean and free of debris inside and outside of the tank
- 1 year limited warranty

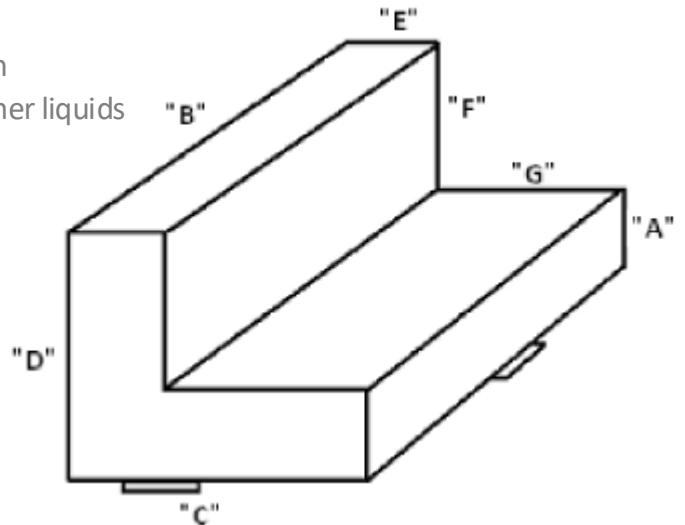

Part #	"A"	"B"	"C"	"D"	"E"	"F"	"G"	Gallons
TTL80	9 1/2"	48 1/2"	28"	26"	8"	16 1/2"	20"	80



Aluminum Tank Industries, Inc.

[Return to Table of Contents](#)

95 Gallon Refueling Tank



Mounting tabs extend out 1-1/2"
Add 2-1/2" for cap height

- Special Permit issued by the US Department of Transportation
- Legal for **gas**, diesel, methanol, kerosene, aviation fuel and other liquids
- Commercial grade lockable vent/prevent filler cap
- Fully baffled to reduce movement of contents
- Two-2" npt reinforced bungs for superior strength
- 3/8" npt drain
- Hold down brackets
- Pressure and leak detection test
- Clean and free of debris inside and outside of the tank
- 1 year limited warranty

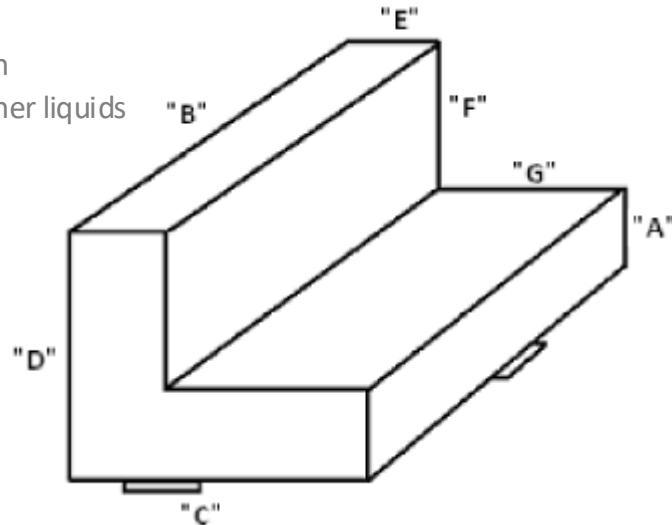

Part #	"A"	"B"	"C"	"D"	"E"	"F"	"G"	Gallons
TTL95	9"	48 1/2"	33"	26"	11	17"	22"	95

TTL100

[Return to Table of Contents](#)



Aluminum Tank Industries, Inc.

100 Gallon Refueling Tank



Mounting tabs extend out 1-1/2"
Add 2-1/2" for cap height

- Special Permit issued by the US Department of Transportation
- Legal for **gas**, diesel, methanol, kerosene, aviation fuel and other liquids
- Commercial grade lockable vent/prevent filler cap
- Fully baffled to reduce movement of contents
- Two-2" npt reinforced bungs for superior strength
- 3/8" npt drain
- Hold down brackets
- Pressure and leak detection test
- Clean and free of debris inside and outside of the tank
- 1 year limited warranty

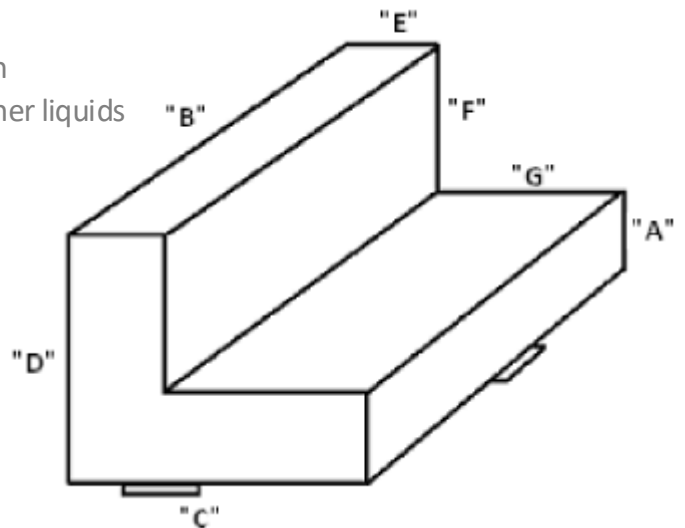

Part #	"A"	"B"	"C"	"D"	"E"	"F"	"G"	Gallons
TTL100	9"	60"	31"	24"	9"	15"	22"	100

TTR38

[Return to Table of Contents](#)



Aluminum Tank Industries, Inc.

38 Gallon Refueling Tank



- Special Permit issued by the US Department of Transportation
- Legal for **gas**, diesel, methanol, kerosene, aviation fuel and other liquids
- Commercial grade lockable vent/prevent filler cap
- Fully baffled to reduce movement of contents
- Two-2" npt reinforced bungs for superior strength
- 3/8" npt drain
- Hold down brackets
- Pressure and leak detection test
- Clean and free of debris inside and outside of the tank
- 1 year limited warranty

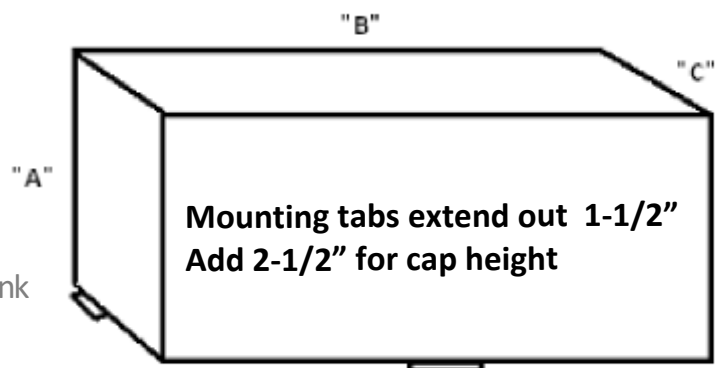

Part #	"A"	"B"	"C"	"D"	"E"	"F"	"G"	Gallons
TTR38	19"	48 1/2"	11"					38

TTR42

[Return to Table of Contents](#)



Aluminum Tank Industries, Inc.

42 Gallon Refueling Tank



- Special Permit issued by the US Department of Transportation
- Legal for **gas**, diesel, methanol, kerosene, aviation fuel and other liquids
- Commercial grade lockable vent/prevent filler cap
- Fully baffled to reduce movement of contents
- Two-2" npt reinforced bungs for superior strength
- 3/8" npt drain
- Hold down brackets
- Pressure and leak detection test
- Clean and free of debris inside and outside of the tank
- 1 year limited warranty

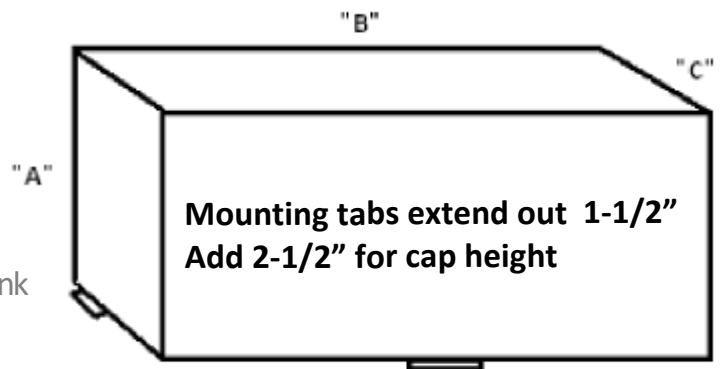

Part #	"A"	"B"	"C"	"D"	"E"	"F"	"G"	Gallons
TTR42	12"	48 1/2"	19"					42

TTR43

[Return to Table of Contents](#)



Aluminum Tank Industries, Inc.

43 Gallon Refueling Tank

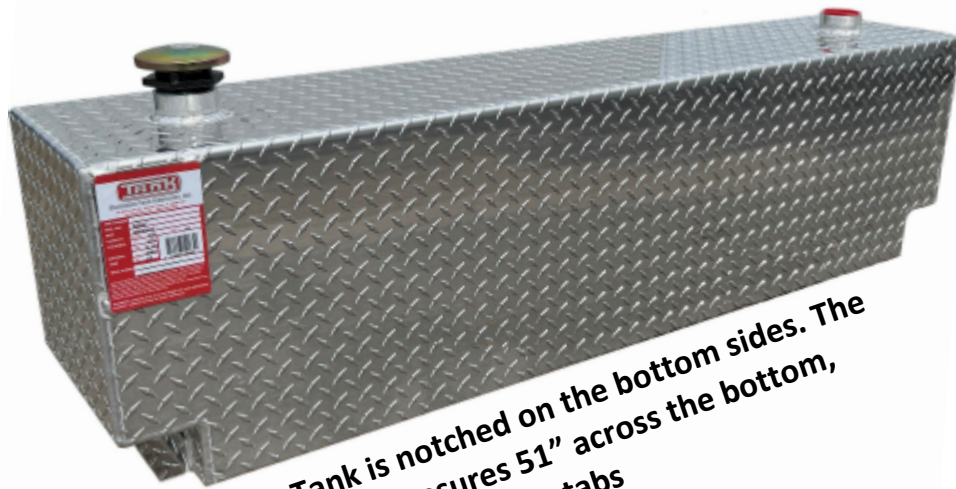

Tank is notched on the bottom sides. The tank measures 51" across the bottom, 54" including the tabs

- Special Permit issued by the US Department of Transportation
- Legal for **gas**, diesel, methanol, kerosene, aviation fuel and other liquids
- Commercial grade lockable vent/prevent filler cap
- Fully baffled to reduce movement of contents
- Two-2" npt reinforced bungs for superior strength
- 3/8" npt drain
- Hold down brackets
- Pressure and leak detection test
- Clean and free of debris inside and outside of the tank
- 1 year limited warranty

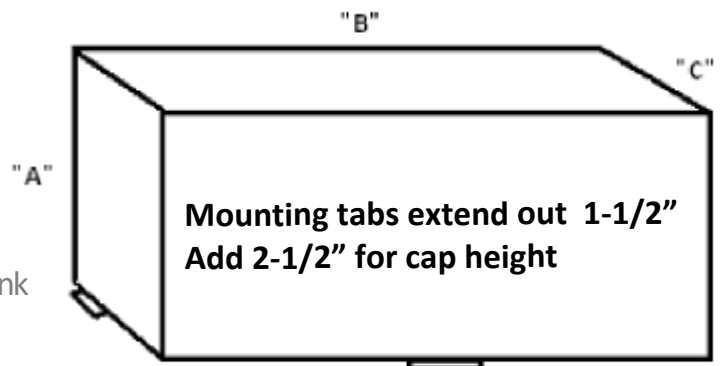

Part #	"A"	"B"	"C"	"D"	"E"	"F"	"G"	Gallons
TTR43	16 1/2"	58"	12"					43

TTR46

[Return to Table of Contents](#)



Aluminum Tank Industries, Inc.

46 Gallon Refueling Tank



- Special Permit issued by the US Department of Transportation
- Legal for **gas**, diesel, methanol, kerosene, aviation fuel and other liquids
- Commercial grade lockable vent/prevent filler cap
- Fully baffled to reduce movement of contents
- Two-2" npt reinforced bungs for superior strength
- 3/8" npt drain
- Hold down brackets
- Pressure and leak detection test
- Clean and free of debris inside and outside of the tank
- 1 year limited warranty

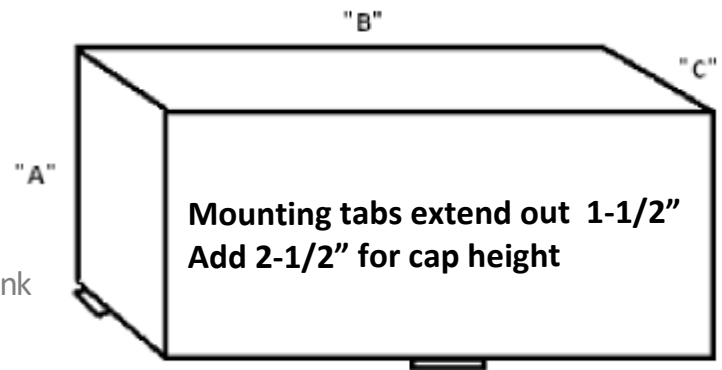

Part #	"A"	"B"	"C"	"D"	"E"	"F"	"G"	Gallons
TTR46	16 1/2"	57"	12"					46

TTR50

[Return to Table of Contents](#)



Aluminum Tank Industries, Inc.

50 Gallon Refueling Tank



- Special Permit issued by the US Department of Transportation
- Legal for **gas**, diesel, methanol, kerosene, aviation fuel and other liquids
- Commercial grade lockable vent/prevent filler cap
- Fully baffled to reduce movement of contents
- Two-2" npt reinforced bungs for superior strength
- 3/8" npt drain
- Hold down brackets
- Pressure and leak detection test
- Clean and free of debris inside and outside of the tank
- 1 year limited warranty

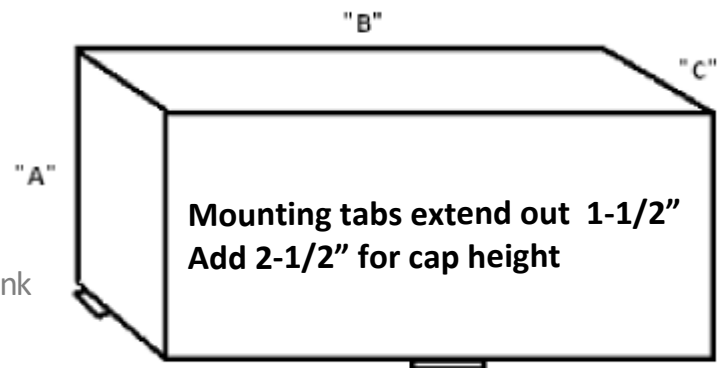

Part #	"A"	"B"	"C"	"D"	"E"	"F"	"G"	Gallons
TTR50	18 1/4"	36 1/4"	19 1/4"					50

TTR51

[Return to Table of Contents](#)



Aluminum Tank Industries, Inc.

51 Gallon Refueling Tank

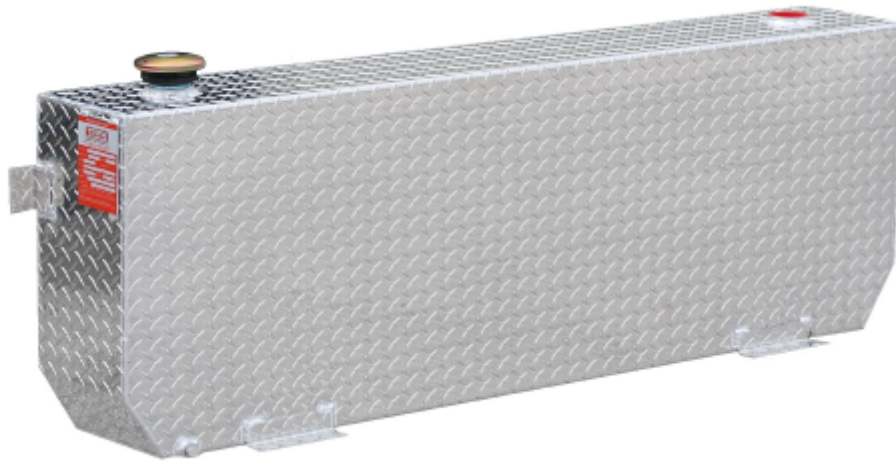

- Special Permit issued by the US Department of Transportation
- Legal for **gas**, diesel, methanol, kerosene, aviation fuel and other liquids
- Commercial grade lockable vent/prevent filler cap
- Fully baffled to reduce movement of contents
- Two-2" npt reinforced bungs for superior strength
- 3/8" npt drain
- Hold down brackets
- Pressure and leak detection test
- Clean and free of debris inside and outside of the tank
- 1 year limited warranty

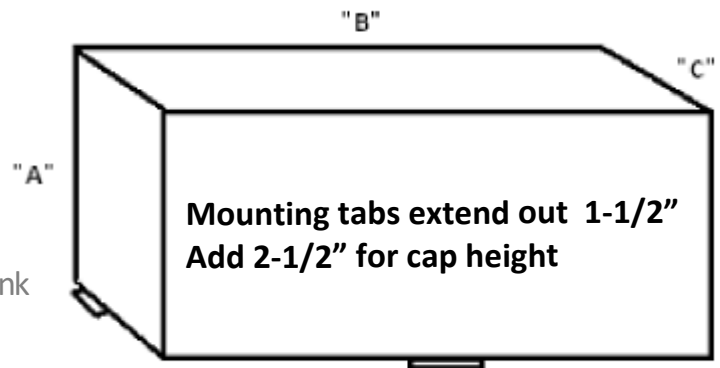

TTR51 is 55" across bottom - Sides of tank taper in at bottom

Part #	"A"	"B"	"C"	"D"	"E"	"F"	"G"	Gallons
TTR51	23 1/2"	60"	9"					51

TTR55

[Return to Table of Contents](#)



Aluminum Tank Industries, Inc.

55 Gallon Refueling Tank



- Special Permit issued by the US Department of Transportation
- Legal for **gas**, diesel, methanol, kerosene, aviation fuel and other liquids
- Commercial grade lockable vent/prevent filler cap
- Fully baffled to reduce movement of contents
- Two-2" npt reinforced bungs for superior strength
- 3/8" npt drain
- Hold down brackets
- Pressure and leak detection test
- Clean and free of debris inside and outside of the tank
- 1 year limited warranty

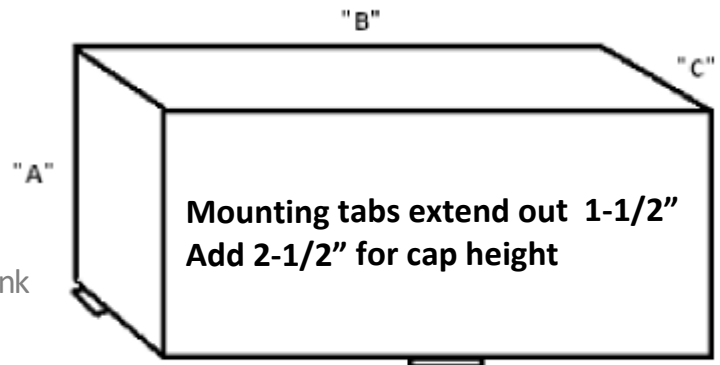

Part #	"A"	"B"	"C"	"D"	"E"	"F"	"G"	Gallons
TTR55	23 1/2"	24 1/4"	24"					55

TTR58

[Return to Table of Contents](#)



Aluminum Tank Industries, Inc.

58 Gallon Refueling Tank



- Special Permit issued by the US Department of Transportation
- Legal for **gas**, diesel, methanol, kerosene, aviation fuel and other liquids
- Commercial grade lockable vent/prevent filler cap
- Fully baffled to reduce movement of contents
- Two-2" npt reinforced bungs for superior strength
- 3/8" npt drain
- Hold down brackets
- Pressure and leak detection test
- Clean and free of debris inside and outside of the tank
- 1 year limited warranty

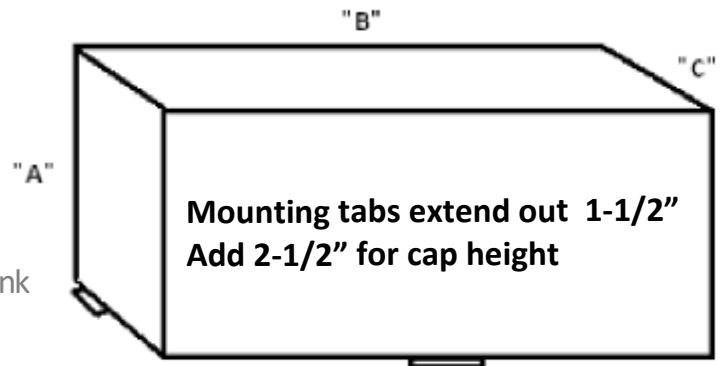

TTR58 is 51" across bottom (54" with tabs)- Sides of tank notched at bottom

Part #	"A"	"B"	"C"	"D"	"E"	"F"	"G"	Gallons
TTR58	13"	58"	21"					58

[Return to Table of Contents](#)



Aluminum Tank Industries, Inc.

62 Gallon Refueling Tank



- Special Permit issued by the US Department of Transportation
- Legal for **gas**, diesel, methanol, kerosene, aviation fuel and other liquids
- Commercial grade lockable vent/prevent filler cap
- Fully baffled to reduce movement of contents
- Two-2" npt reinforced bungs for superior strength
- 3/8" npt drain
- Hold down brackets
- Pressure and leak detection test
- Clean and free of debris inside and outside of the tank
- 1 year limited warranty

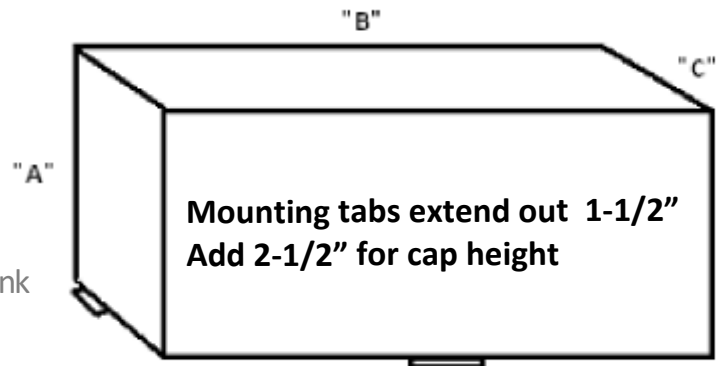

TTR65 is 54" across bottom - Sides of tank angled at bottom

Part #	"A"	"B"	"C"	"D"	"E"	"F"	"G"	Gallons
TTR65	13"	60"	21"					62

TTR77

[Return to Table of Contents](#)



Aluminum Tank Industries, Inc.

77 Gallon Refueling Tank



- Special Permit issued by the US Department of Transportation
- Legal for **gas**, diesel, methanol, kerosene, aviation fuel and other liquids
- Commercial grade lockable vent/prevent filler cap
- Fully baffled to reduce movement of contents
- Two-2" npt reinforced bungs for superior strength
- 3/8" npt drain
- Hold down brackets
- Pressure and leak detection test
- Clean and free of debris inside and outside of the tank
- 1 year limited warranty

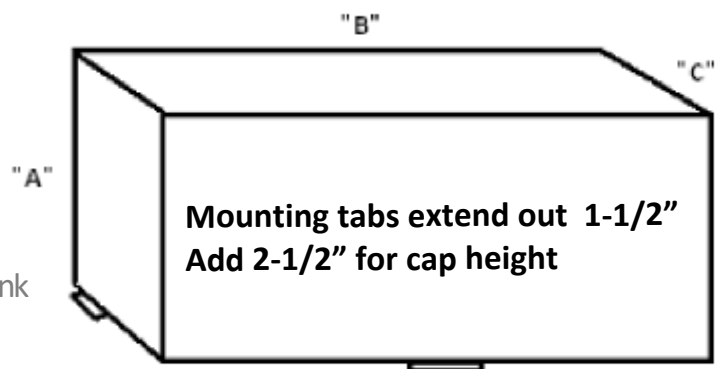

Part #	"A"	"B"	"C"	"D"	"E"	"F"	"G"	Gallons
TTR77	19"	57"	18"					77

TTR110

[Return to Table of Contents](#)



Aluminum Tank Industries, Inc.

110 Gallon Refueling Tank

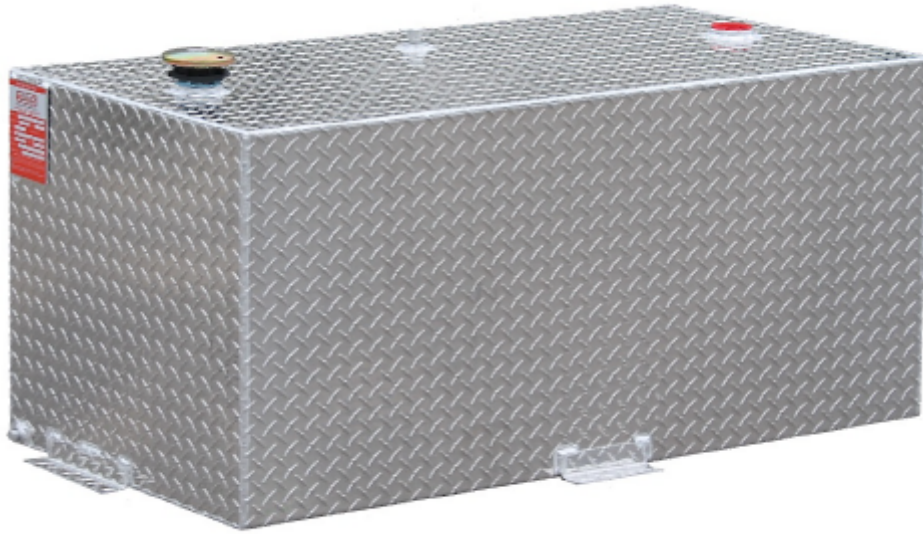

- Special Permit issued by the US Department of Transportation
- Legal for **gas**, diesel, methanol, kerosene, aviation fuel and other liquids
- Commercial grade lockable vent/prevent filler cap
- Fully baffled to reduce movement of contents
- Two-2" npt reinforced bungs for superior strength
- 3/8" npt drain
- Hold down brackets
- Pressure and leak detection test
- Clean and free of debris inside and outside of the tank
- 1 year limited warranty

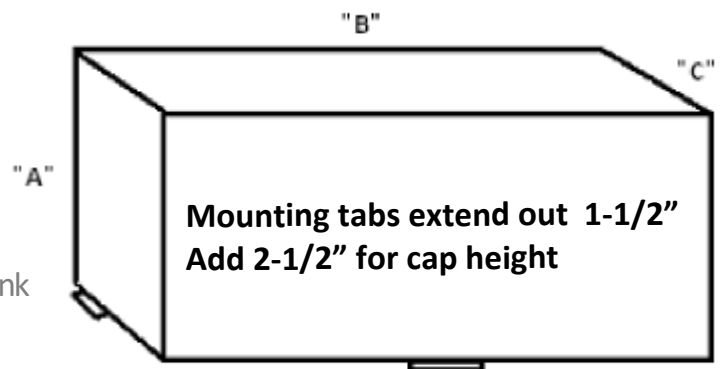

Part #	"A"	"B"	"C"	"D"	"E"	"F"	"G"	Gallons
TTR110	23 1/2"	48 1/2"	24"					110

TTW60

[Return to Table of Contents](#)



Aluminum Tank Industries, Inc.

60 Gallon Wedge Refueling Tank



- Mounting tabs extend out 1-1/2"
- Add 2-1/2" for cap height

- Special Permit issued by the US Department of Transportation
- Legal for **gas**, diesel, methanol, kerosene, aviation fuel and other liquids
- Commercial grade lockable vent/prevent filler cap
- Fully baffled to reduce movement of contents
- Two-2" npt reinforced bungs for superior strength
- 3/8" npt drain
- Hold down brackets
- Pressure and leak detection test
- Clean and free of debris inside and outside of the tank
- 1 year limited warranty

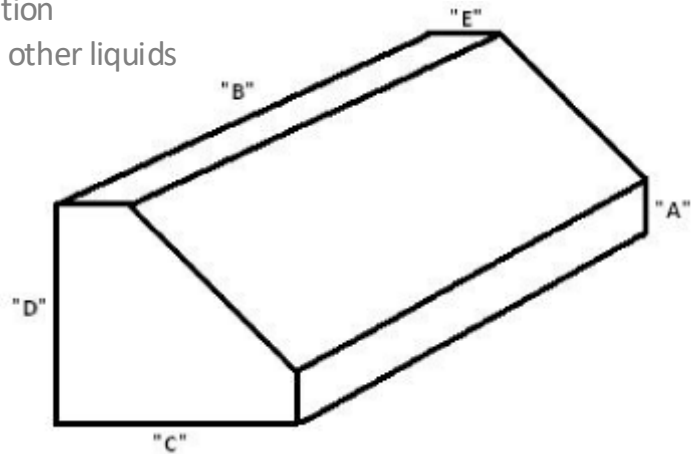

Part #	"A"	"B"	"C"	"D"	"E"	"F"	"G"	Gallons
TTW60	4"	56"	20"	18"	6"			60

TTR98DW

[Return to Table of Contents](#)



Aluminum Tank Industries, Inc.

98 Gal Double Wall Tank



- Special Permit issued by the US Department of Transportation
- Legal for **gas**, diesel, methanol, kerosene, aviation fuel and other liquids
- Commercial grade lockable vent/prevent filler cap
- Fully baffled to reduce movement of contents
- Two-2" npt reinforced bungs for superior strength
- 3/8" npt drain
- Hold down brackets
- Pressure and leak detection test
- Clean and free of debris inside and outside of the tank
- 1 year limited warranty

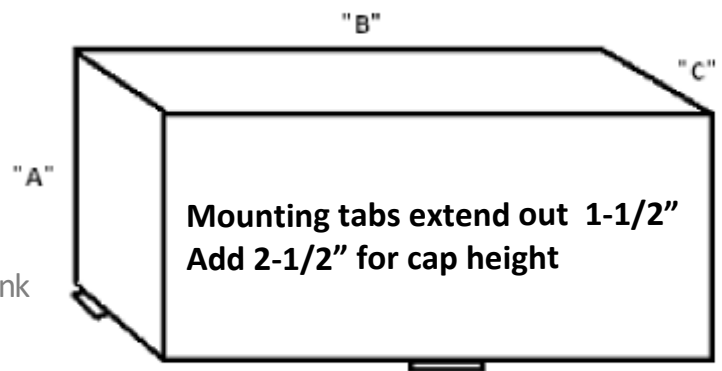

Part #	"A"	"B"	"C"	"D"	"E"	"F"	"G"	Gallons
TTR98DW	25"	48"	26"					98

TTR110DW

[Return to Table of Contents](#)



Aluminum Tank Industries, Inc.

110 Gal Double Wall Tank



- Special Permit issued by the US Department of Transportation
- Legal for **gas**, diesel, methanol, kerosene, aviation fuel and other liquids
- Commercial grade lockable vent/prevent filler cap
- Fully baffled to reduce movement of contents
- Two-2" npt reinforced bungs for superior strength
- 3/8" npt drain
- Hold down brackets
- Pressure and leak detection test
- Clean and free of debris inside and outside of the tank
- 1 year limited warranty

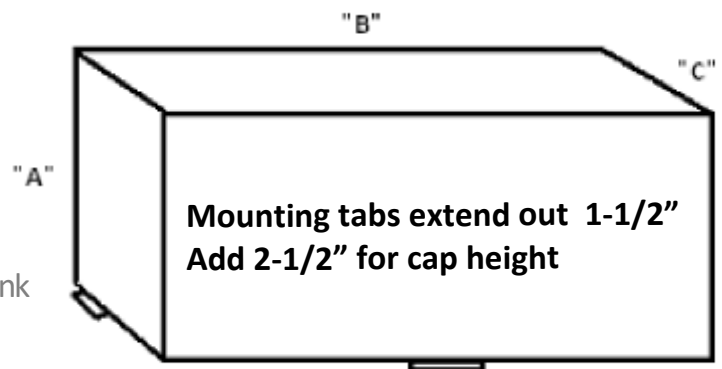

Part #	"A"	"B"	"C"	"D"	"E"	"F"	"G"	Gallons
TTR110DW	25"	53"	26"					110

[Return to Table of Contents](#)



Aluminum Tank Industries, Inc.

72 Gallon Split Refueling Tank

Need to Transport 2 different liquids?
GOTCHA!



- Mounting tabs extend out 1-1/2"
- Add 2-1/2" for cap height

- Special Permit issued by the US Department of Transportation
- Legal for **gas**, diesel, methanol, kerosene, aviation fuel and other liquids
- Commercial grade lockable vent/prevent filler cap
- Fully baffled to reduce movement of contents
- Two-2" npt reinforced bungs for superior strength
- 3/8" npt drain
- Hold down brackets
- Pressure and leak detection test
- Clean and free of debris inside and outside of the tank
- 1 year limited warranty

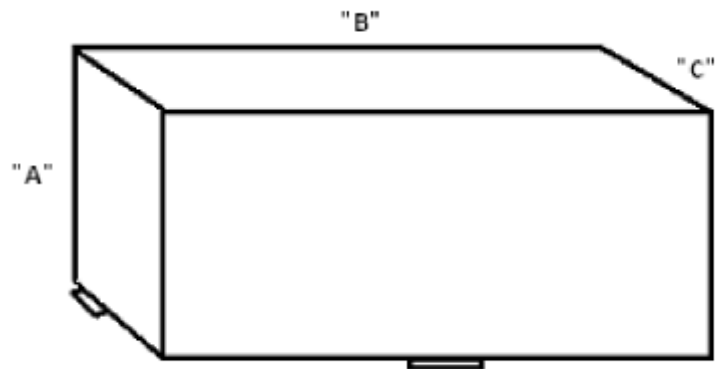

Part #	"A"	"B"	"C"	"D"	"E"	"F"	"G"	Gallons
TTR72S	18"	57"	18"					36/36

TTL85S



Aluminum Tank Industries, Inc.

[Return to Table of Contents](#)

85 Gallon Split Refueling Tank



Need to Transport 2 different liquids?
GOTCHA!

- Mounting tabs extend out 1-1/2"
- Add 2-1/2" for cap height

- Special Permit issued by the US Department of Transportation
- Legal for **gas**, diesel, methanol, kerosene, aviation fuel and other liquids
- Commercial grade lockable vent/prevent filler cap
- Fully baffled to reduce movement of contents
- Two-2" npt reinforced bungs for superior strength
- 3/8" npt drain
- Hold down brackets
- Pressure and leak detection test
- Clean and free of debris inside and outside of the tank
- 1 year limited warranty

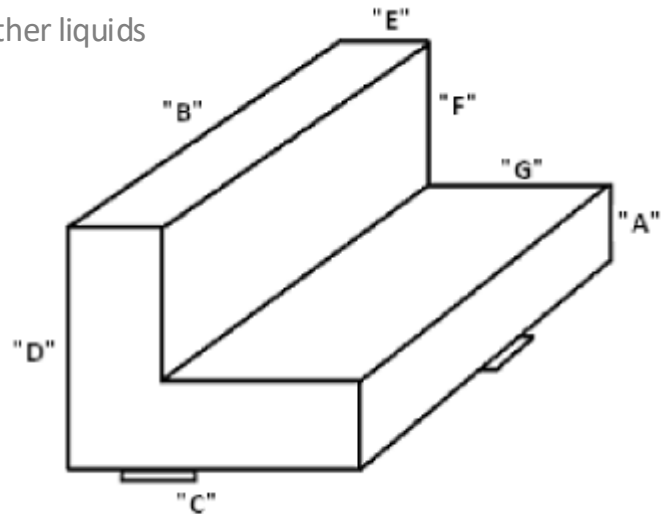

Part #	"A"	"B"	"C"	"D"	"E"	"F"	"G"	Gallons
TTL85S	9"	57"	30"	24"	9"	15"	21"	42/42

TTL95S

[Return to Table of Contents](#)



Aluminum Tank Industries, Inc.

95 Gallon Split Refueling Tank



Need to Transport 2 different liquids?
GOTCHA!

- Mounting tabs extend out 1-1/2"
- Add 2-1/2" for cap height

- Special Permit issued by the US Department of Transportation
- Legal for **gas**, diesel, methanol, kerosene, aviation fuel and other liquids
- Commercial grade lockable vent/prevent filler cap
- Fully baffled to reduce movement of contents
- Two-2" npt reinforced bungs for superior strength
- 3/8" npt drain
- Hold down brackets
- Pressure and leak detection test
- Clean and free of debris inside and outside of the tank
- 1 year limited warranty

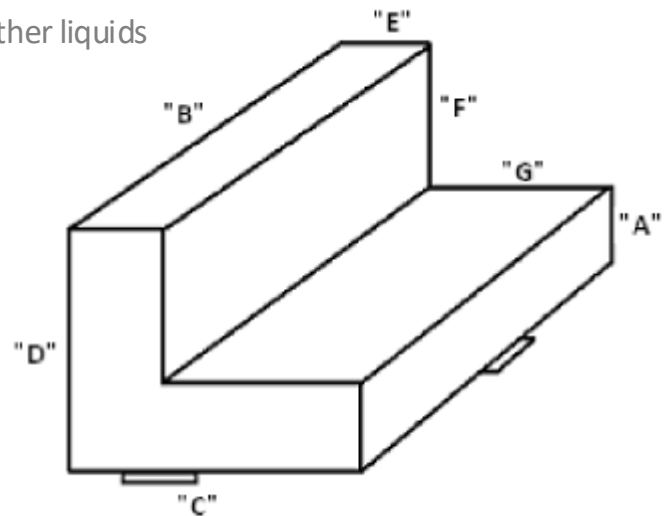

Part #	"A"	"B"	"C"	"D"	"E"	"F"	"G"	Gallons
TTL95S	9"	48 1/2"	33"	26"	11"	17"	22"	47/47

TTR110S

[Return to Table of Contents](#)



Aluminum Tank Industries, Inc.

110 Gallon Split Refueling Tank

Need to Transport 2 different liquids?
GOTCHA!



- Mounting tabs extend out 1-1/2"
- Add 2-1/2" for cap height

- Special Permit issued by the US Department of Transportation
- Legal for **gas**, diesel, methanol, kerosene, aviation fuel and other liquids
- Commercial grade lockable vent/prevent filler cap
- Fully baffled to reduce movement of contents
- Two-2" npt reinforced bungs for superior strength
- 3/8" npt drain
- Hold down brackets
- Pressure and leak detection test
- Clean and free of debris inside and outside of the tank
- 1 year limited warranty

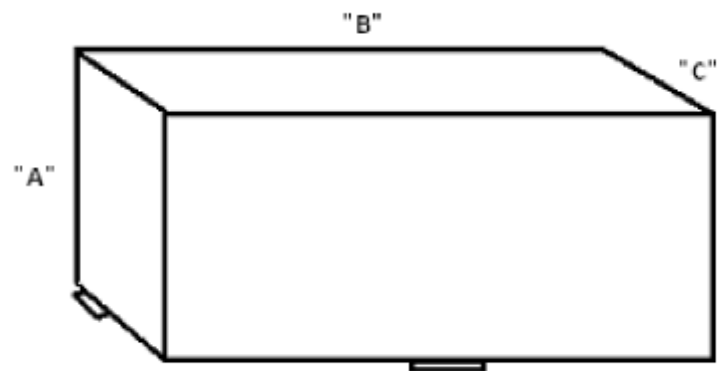

Part #	"A"	"B"	"C"	"D"	"E"	"F"	"G"	Gallons
TTR110S	23 1/2"	48 1/2"	24"					55/55

TTR42CB

[Return to Table of Contents](#)



Aluminum Tank Industries, Inc.

42 Gallon Refueling Tank/Toolbox Combo



Tank Toolbox Combos

Refueling Tank and Toolbox combos are great, secure solutions for tool and equipment storage as well as on the go fueling! The toolbox features:

- All polished aluminum DP body construction
- Polished industrial stainless locking handles
- Automotive style gas shocks for lid
- Extreme 3 layer lid design
- Full aluminum piano hinge
- Aero-beveled lid design

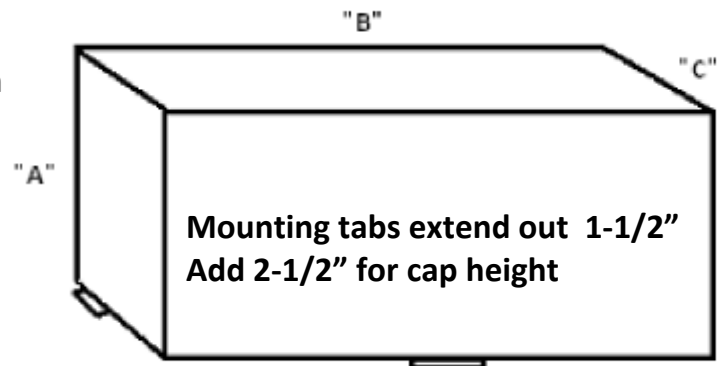

Part #	"A"	"B"	"C"	"D"	"E"	"F"	"G"	Gallons
TTR42CB	21"	48 1/2"	19"	Toolbox is 36" x 19" x 9"				42

[Return to Table of Contents](#)



Aluminum Tank Industries, Inc.

47 Gallon Refueling Tank/Toolbox Combo



Tank Toolbox Combos

Refueling Tank and Toolbox combos are great, secure solutions for tool and equipment storage as well as on the go fueling! The toolbox features:

- All polished aluminum DP body construction
- Polished industrial stainless locking handles
- Automotive style gas shocks for lid
- Extreme 3 layer lid design
- Full aluminum piano hinge
- Aero-beveled lid design

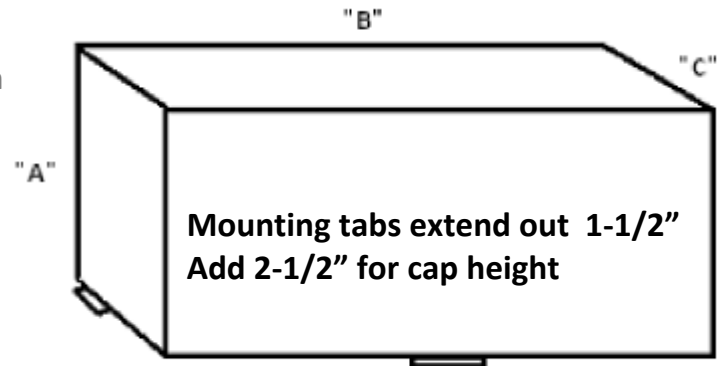

Part #	"A"	"B"	"C"	"D"	"E"	"F"	"G"	Gallons
TTL50CB	18"	36 1/4"	29"	Toolbox is 36" x 19" x 9"				47

TTR58CB

[Return to Table of Contents](#)



Aluminum Tank Industries, Inc.

58 Gallon Refueling Tank/Toolbox Combo



Tank Toolbox Combos

Refueling Tank and Toolbox combos are great, secure solutions for tool and equipment storage as well as on the go fueling! The toolbox features:

- All polished aluminum DP body construction
- Polished industrial stainless locking handles
- Automotive style gas shocks for lid
- Extreme 3 layer lid design
- Full aluminum piano hinge
- Aero-beveled lid design

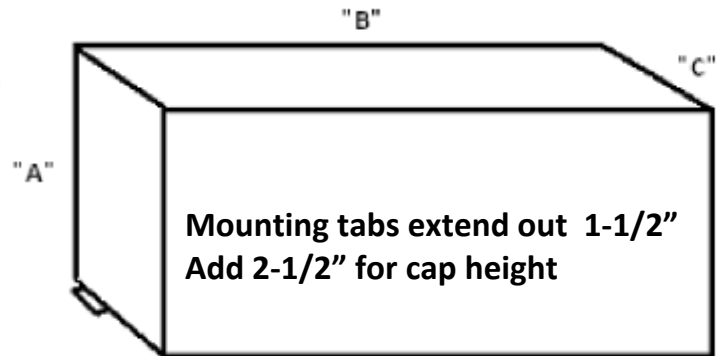

TTR58 is 51" across bottom (54" with tabs)- Sides of tank notched at bottom

Part #	"A"	"B"	"C"	"D"	"E"	"F"	"G"	Gallons
TTR58CB9	21"	58"	21"	Toolbox is 42" x 19" x 9"				58

TTL95CB

[Return to Table of Contents](#)



Aluminum Tank Industries, Inc.

95 Gallon Refueling Tank/Toolbox Combo



Tank Toolbox Combos

Refueling Tank and Toolbox combos are great, secure solutions for tool and equipment storage as well as on the go fueling! The toolbox features:

- All polished aluminum DP body construction
- Polished industrial stainless locking handles
- Automotive style gas shocks for lid
- Extreme 3 layer lid design
- Full aluminum piano hinge
- Aero-beveled lid design

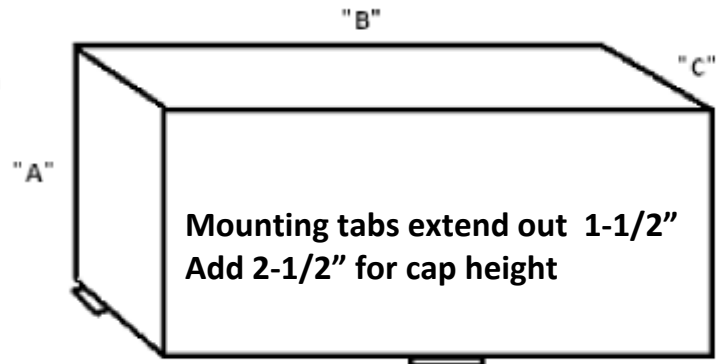

Part #	"A"	"B"	"C"	"D"	"E"	"F"	"G"	Gallons
TTL95CB	26"	48 1/2"	33"	Toolbox is 48" x 22" x 17"				95

[Return to Table of Contents](#)



Aluminum Tank Industries, Inc.

95 Gal SPLIT Refueling Toolbox Combo

Need to Transport 2 different liquids?
GOTCHA!



Tank Toolbox Combos

Refueling Tank and Toolbox combos are great, secure solutions for tool and equipment storage as well as on the go fueling! The toolbox features:

- All polished aluminum DP body construction
- Polished industrial stainless locking handles
- Automotive style gas shocks for lid
- Extreme 3 layer lid design
- Full aluminum piano hinge
- Aero-beveled lid design

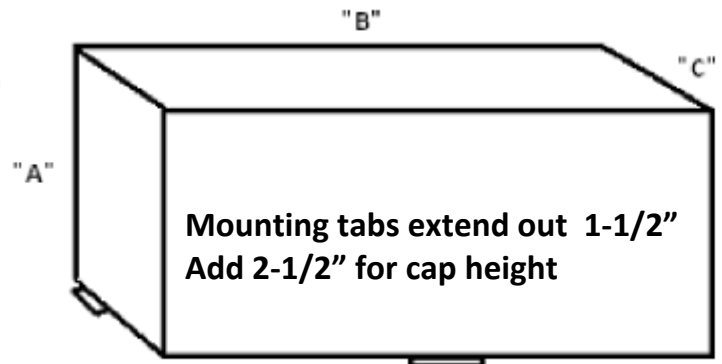

Part #	"A"	"B"	"C"	"D"	"E"	"F"	"G"	Gallons
TTL95SCB	26"	48 1/2"	33"	Toolbox is 48" x 22" x 17"				47/47

SSL95

[Return to Table of Contents](#)



Aluminum Tank Industries, Inc.



95 Gal Refueling Tank



Severe Fuel Cap

.190" HD Aluminum



Aluminum Tank Industries **SEVERE SERIES** refueling tanks were designed for severe conditions. The tank offers these features:

- ❖ Lockable SpinSecure vent/prevent cap.
- ❖ Fully welded tank baffles.
- ❖ Unique internal pump bung supports.
- ❖ 50% thicker, heavier .190" HD aluminum construction.
- ❖ Vent with rollover protection for SAFETY and functionality.
- ❖ Two 2" bungs for mounting the pump on either side.
- ❖ Special Permit for use in commerce.
- ❖ Designed for gasoline, diesel, kerosene, Av fuel, and methanol.
- ❖ DOT permit allows transportation while the pump is attached.
- ❖ *5 year warranty.

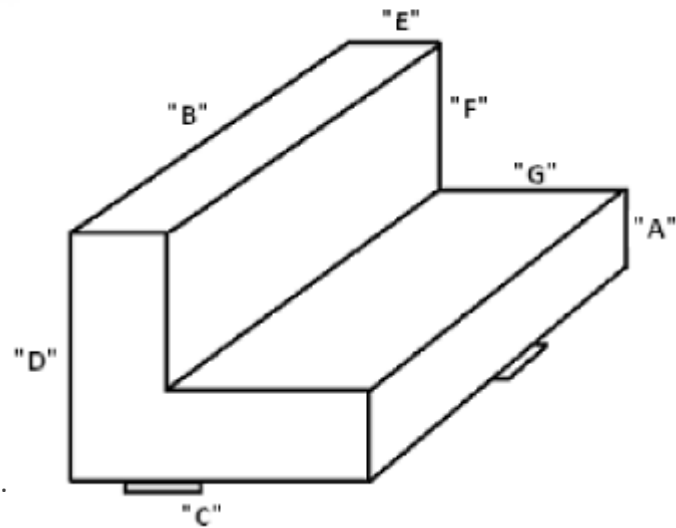

- Mounting tabs extend out 1-1/2"
- Add 2-1/2" for cap height

Part #	"A"	"B"	"C"	"D"	"E"	"F"	"G"	Gallons
SSL95	9"	48 1/2"	33"	26"	11"	17"	22"	95

SSL95CB

[Return to Table of Contents](#)



Aluminum Tank Industries, Inc.



95 Gal Tank Combo



Severe Fuel Cap



*.190" HD Aluminum Tank
.063 HD Toolbox*

Aluminum Tank Industries **SEVERE SERIES** refueling tanks were designed for severe conditions. The tank offers these features:

- ❖ Lockable SpinSecure vent/prevent cap.
- ❖ Fully welded tank baffles.
- ❖ Unique internal pump bung supports.
- ❖ 50% thicker, heavier .190" HD aluminum construction.
- ❖ Vent with rollover protection for SAFETY and functionality.
- ❖ Two 2" bungs for mounting the pump on either side.
- ❖ Special Permit for use in commerce.
- ❖ Designed for gasoline, diesel, kerosene, Av fuel, and methanol.
- ❖ DOT permit allows transportation while the pump is attached.
- ❖ *5 year warranty.

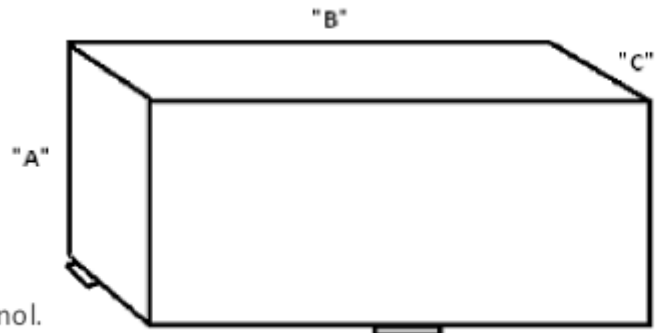

**Mounting tabs extend out 1-1/2"
Add 2-1/2" for cap height**

Part #	"A"	"B"	"C"	"D"	"E"	"F"	"G"	Gallons
SSL95CB	9"	48 1/2"	33"	26"	11	17"	22"	95

SSR110

[Return to Table of Contents](#)



Aluminum Tank Industries, Inc.



110 Gal Refueling Tank



Severe Fuel Cap



.190" HD Aluminum Tank

Aluminum Tank Industries **SEVERE SERIES** refueling tanks were designed for severe conditions. The tank offers these features:

- ❖ Lockable SpinSecure vent/prevent cap.
- ❖ Fully welded tank baffles.
- ❖ Unique internal pump bung supports.
- ❖ 50% thicker, heavier .190" HD aluminum construction.
- ❖ Vent with rollover protection for SAFETY and functionality.
- ❖ Two 2" bungs for mounting the pump on either side.
- ❖ Special Permit for use in commerce.
- ❖ Designed for gasoline, diesel, kerosene, Av fuel, and methanol.
- ❖ DOT permit allows transportation while the pump is attached.
- ❖ *5 year warranty.

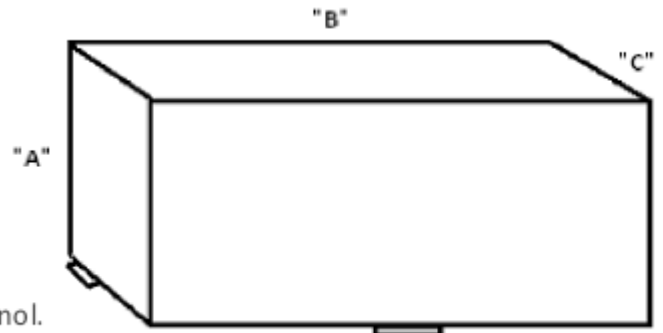

**Mounting tabs extend out 1-1/2"
Add 2-1/2" for cap height**

Part #	"A"	"B"	"C"	"D"	"E"	"F"	"G"	Gallons
SSR110	24"	48 1/2"	24"					110